

BUGELFLASCHE 50 CL

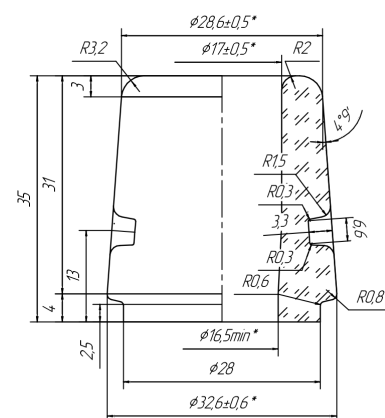
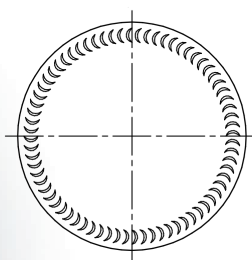
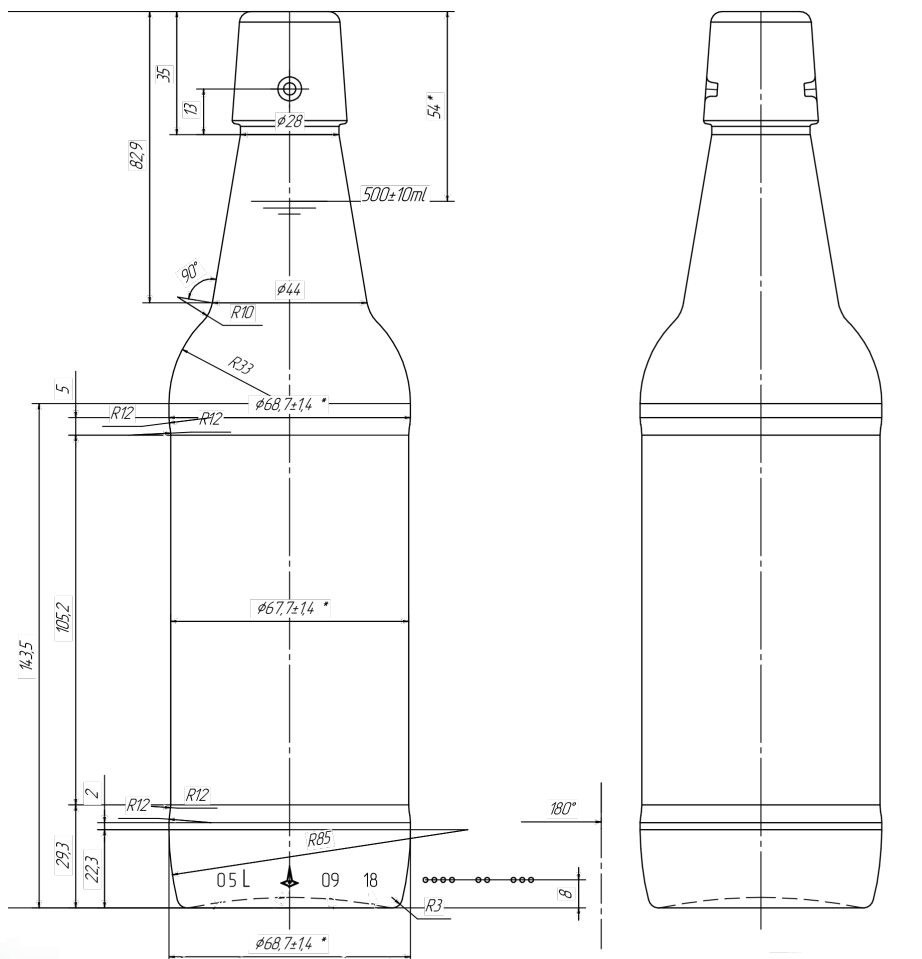

Denominación

Bugelflasche 0,5l MW

Cap a verter / Brimfull

520 ± 10

Cap de llenado / At fill line

500 ml

Peso / Weight

375 g

Presión Hidrostática

16 kgm/cm²

Resistencia Térmica

50 °C